Technical Specification

Automatic Load Bank AC415-500kW



T-power Pty Ltd

1 System Overview

1.1 Foreword

(1) According to the special requirements of users on site, in the agreement the technical standards of AC415-500kW Automatic Load Bank (hereinafter referred to as "system") and its accessories are proposed including their function, performance, usage, structure, installation and test to provide users with a high efficient and reliable choice, in order to meet the need for generator load test.

(2) The system consists of 1 sets of 500kW Resistive load bank. The System is made up of two parts of measurement and control and load, mainly including AC dry load, automatic data acquisition system, automatically loading and unloading control system, the cooling device, auxiliary control, PC software and so on.

(3) This system, which is of independent research and development of electricity load test equipment by our technology, combining dry load module with the automatic measurement and control module, can accurately detect all kinds of generator output power and load capacity, full load and overload test.

The system can be used with a computer to realize the intelligent control, automatically completing the special test to all electrical parameters of generating set and generating tables, graphs, and supporting the print, comprehensively from the cumbersome manual operation to provide scientific and efficient detection means for the power generating sets.

(4) All the schematic diagrams of this agreement are for reference only please in kind prevail

1.2 Testing System



Note: Power cable and PC, remote controller, printer are not available. If need them, prices will be checked.

Picture just for reference, subject to the real products.

1.3 System Characteristics

1.3.1 The system is a self-developed device used for electricity load testing by Toprail Technology. It perfectly combines the dry type load module and measurement and control module, precisely test output power and load performance of kinds of generator set.

System mainly consists of resistance load, data collecting, control system, cooling device, etc. The system can test output power and load performance of generator sets.

1.3.2 System can load power in rated range, measure generator steady-state 3 phase voltage, current, active power, reactive power, apparent power, power factor, frequency, and running time, and simulate the generator set real load working state. Power input using sectional type, energy dissipation type load, forced-air cooling, 3 phase fan decentralized supply air, air-flow is sufficient and low noise.

1.3.3 System can work with PC software to realize intelligent operation, automatically finish the parameter testing, and create testing data table, curves and reports that can be printed, reduce a lot of manual operation.

1.4 Supply List

The following form presents the accessories provided when we make shipment.

Items	Quantity	Remark
AC415-500kW Automatic Load Bank	1	
RS485 or RS232	1	10 meters
RS232, RS485, USB Converter	1	
Product Instruction	1	
Certification	1	
Warranty Card	1	1 year
Packing List	1	
Receiving Apron	1	
Data Processing Software	1	
Test Report	1	

1.5 Manufacturing Standards

Design of intelligent test system of generator unit, production and services are in strict accordance with the GB/T19001-2008 "quality management system" requirements, and refer to the following standards. Some standards may not be suitable for practical applications, the technical agreement production plan system finally to agreed prevail.

National standards	
GB7251.1-2005	Low-voltage switchgear assembly and control part
GB/T2681-1981	Colors of insulated conductors used in electrical assembly devices
GB/T11634-2000	Marine AC Low Voltage Switchboard General Specification
GB/T11803-89	Marine AC low voltage switchboard—Construction and basic dimension
GB/T2820.5-2009	Reciprocating internal combustion engine driven alternating current generating sets-part fifth: generator
GB/T13032-2010	Marine diesel generator
GB/T1029-2005	3 phase synchronous motor test method
GB14711-2006	Safety requirements for rotating electrical motor
Military Standards	
GJB2815-97	Military internal combustion engine general specification
GJB235A-97	Military AC move load general specification
GJB235-87	Power, intermediate frequency move load general specification
GJB1488-93	Military internal combustion engine load general test method
Industry standards	
JB/T10303-2001	Generator technical condition

1.6 Main Technology Advantages

Toprail Dummy Load Bank scientific and technology level is in leading position in this industry, besides general functions, it has following unique advantages:

Standard Testing Function: System can do stable test, transient test, and realize functions, such as setting, fluctuation, instant load, and instant unload. The terms and formulas used in test strictly comply with relevant national standard.



High Power Load: high load power density, large capacity of single set, parallel running to finish superpower testing, and realize tens of megawatts of power loading.

Accurate Data: with high precision data collection module and measuring meter, related equipment has passed the certification by CMA (China Metrology Accreditation) qualification testing institution, and ensures the reliability of data.

Flexible Control Mode: based on different using habit, several control modes as following can be choose, local panel operation, remote box controlling, and intelligent software.

Intelligent Loading: after setting generator rated power in software, system realize rapid loading through preset proportion, automatically and continuously load multiple power value and common tests, like stepping, full load, and overload, so that improve working efficiency.

High Efficiency Data Management: display real-time testing data, generate curves graphs automatically, also can put data into storage. According to generator set No. set up testing file, support to query at anytime, and improve data management efficiency.

Comprehensive Protection Function: multiple protection, like over temperature, smoke. When in danger, automatically terminate the test and give alarm to protect safety of personnel and equipment.

Stable Running: with the latest generation control module as the core, a sharp rise in system response speed and anti-

interference performance, avoid function failure in complex electrical environment, and

ensures system running stably and reliably.

New Load Bank Technology: using the international advanced AC load bank technology, overcome the old water bank defects, such as bear bumpy, unable to use when go to sea, realize Mooring Trial and Sea Trail, and simulate the real working condition of generator running.

Mature Manufacturing Technology: load element using excellent anti-corrosion materials; waterproof insulation container packaging, suitable for adverse environment such as ocean. Internally layout is reasonable, air channel is clear, rapid heat emission, and satisfy continuous working need.

2. Technical Parameter

AC415-500kW Automatic Load Bank	
Rating Voltage/Frequency	415V AC 3 phase 4 wire, 50Hz
Rated Load Power	Resistive load: 510kW
Load Step	1kW, 2kW, 2kW, 5kW, 10kW, 20kW, 20kW, 50kW, 100kW, 100kW, 200kW

PF(PowerFactor)	1
LoadTolerance (eachstep)	±5%
LoadTolerance (overall)	±3%
DisplayPrecision	0.5class
ControlPower	External415VAC/50Hz,3phase4wire,240V1-phase
WireConnection	Load powersupplyinput-Copperbar (starcoupling) Controlpowersupplyinput-Connector-bar
Insulation	F
DutyCycle	Continuous
CoolingType	Forceaircooling, horizontalairinletandverticalairoutlet
Transportation	Hoisting,there are liftinglugontopandcastors atthebottomof casing
Dimension	About1540mm*1250mm*1680mm (L×W×H)
Weight	About750kgs
CasingColor	Grey (RAL7035) orasrequired
OperatingEnvironmentParameter	
Workplace	Indoor
AmbientTemperature	-20℃ ~ +50℃
RelativeHumidity	≤95%
Altitude	≤2500meter
AtmosphericPressure	86 ~ 106kPa
Brandsof MainComponents	
Contactora	Schneider
Fuse	Miro
PLC	Siemens
DataProcessing Software	TopRailServices (self-developed)
AlloyResistance	TopRailServices (self-developed)

3. FunctionIntroduction

- 1) User could load any power within rated power, can test stable state three-phase voltage, current,activepower,reactivepower,apparentpower,powerfactor,frequency,runningtimeofgeneratingset.
- 2) Whether load/unload by manual control panel, remote control or by PC softwarecontrol, usercanpre-setthepowerthenpressthemasterload button.
- 3) Control mode: user can choose local manual control, remote control or Intelligent control(PCcontrol)

- 3.1 Local manual control: there is local control panel in load bank, with multi load steps, min loadsteps1kW,controlled by buttons.
- 3.2 Remotecontrol:remotecontrollerconnectedtheloadbankwithcontrolcable.(optional)
- 3.3 Intelligent control: user can control load bank by data processing software of PC to makeautomatic load/unload, display, record and manager the test data, form curve, graph and can beprinted.
- 4) Controlmodeinterlock:thereisswitchincontrolpaneltochoosecontrolmode,othercontrolmodeis invalidifuserchooseonecontrol mode.
- 5) Withdataprocessingsoftware,couldformcurveofcurrent,activepower,reactivepower,apparentpower, power factor,frequencyandcanbeprinted.
- 6) One-keyload/unload:usercanloadorunloadwithonekeyeasytocontrol.
- 7) 3lineLEDmulti-functionmeterdisplay.

4. DataProcessingSoftwareFunctions

- 1) Communicationtype:throughRS232,RS485orUSBinterface.
- 2) Loadmode:manualload orautomaticload.
- 3) Manualload:inputpowerandpowerfactor.
- 4) Automaticload:Usercansetseveralperiodsofpowerandtime,andinturnof0%→25%→50%→75%→100%,etc presetorderto make automaticloadtesting.
- 5) Parallel testing: when several load banks parallel working, parameters of each load bank can bedisplayedand recorded,so dothefinalparametersofparalleling working.
- 6) Real-timeparameter:Current,voltage,power,powerfactor,frequency,time,etccouldbedisplayedby software.
- 7) Safetymonitoring:Usercanknowtheworkingconditionsofloadbankthroughsoftwareindicatinglight. Wheninabnormalstopprotection,softwarewillindicatethereasonsofstopping.
- 8) Datacollectioninterval:theminsavingintervalis2seconds.
- 9) Datasavingand inquiry:testingdatacouldbesavedinsoftware, usercan queryatanytime.
- 10) Data display: it could display real-time data and history data; user can print voltage, current,frequency,powergraphs andcharts.
- 11) Charts and graphs are output in format of JPG while testing data output in Excel format, and allcanbeprinted.

5. Protection Function

- 1) **Emergency Stop:** User can press the emergency stop button in the panel to unload immediately when the load bank is abnormal while working.
- 2) **Over-voltage Protection:** Automatic load dump and give alarm when voltage is over safety thresholds.
- 3) **Over-heat Protection:** Automatic load dump and give alarm when temperature is over safety thresholds.
- 4) **Short Circuit Protection:** Equip with fuse, automatic load dump when current is over large.
- 5) **Fan Interlock protection:** Machine could not do load testing before working power off fan is on.
- 6) **Phase Sequence Automatic Conversion Protection** When control power cable in wrong connections, 3 phase fans can also work in good conditions.
- 7) **Protection Button:** there are some protection buttons can be switched off when false alarm or for special requirements.
- 8) **Enclosure Ground Protection:** the load bank with special ground protection terminal to avoid user and risk of electric shock hazard.

6.

SystemDiagram

SchematicDiagram

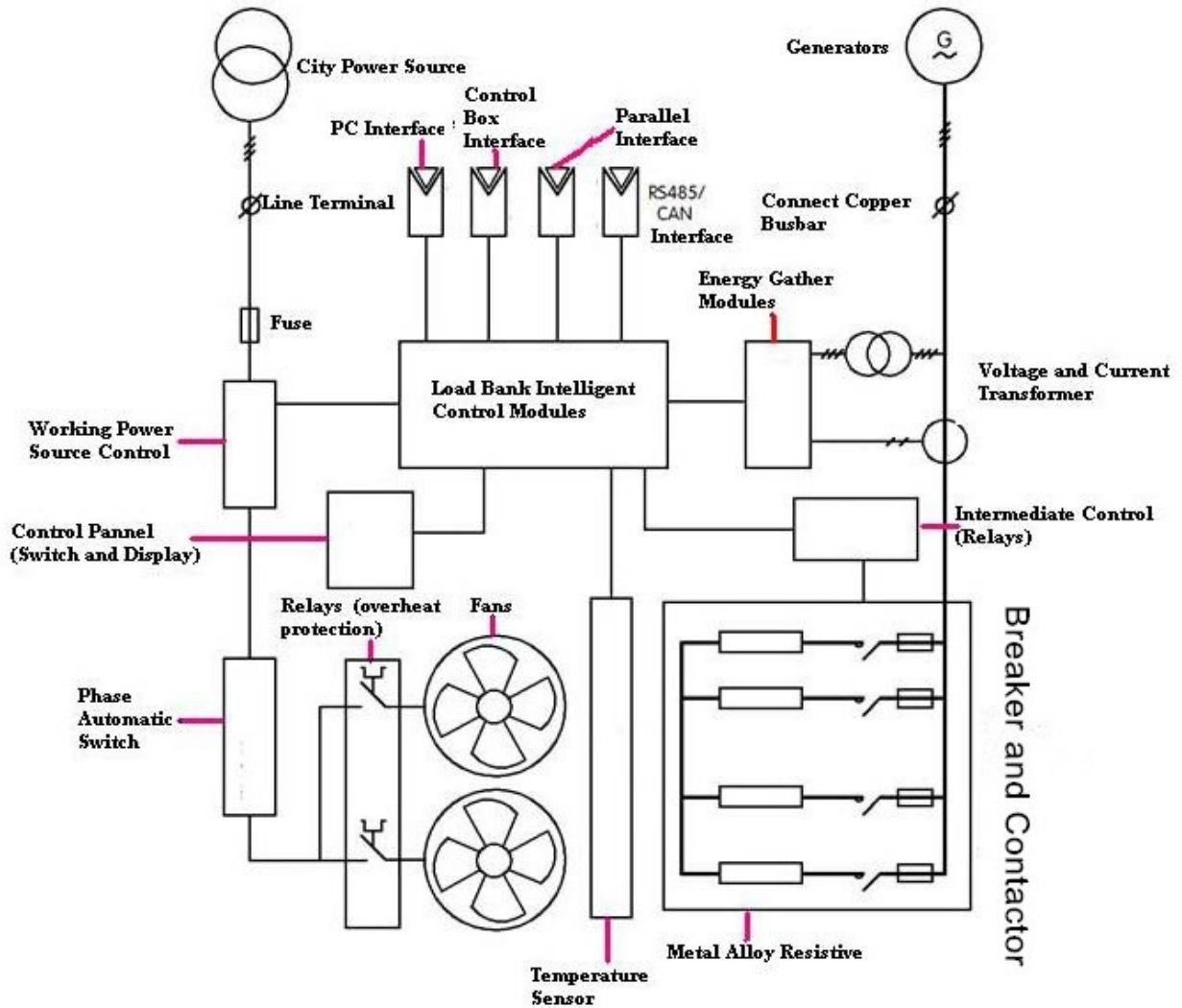

7. LoadBankStructure

Note: Pictures only for reference, subject to the real product

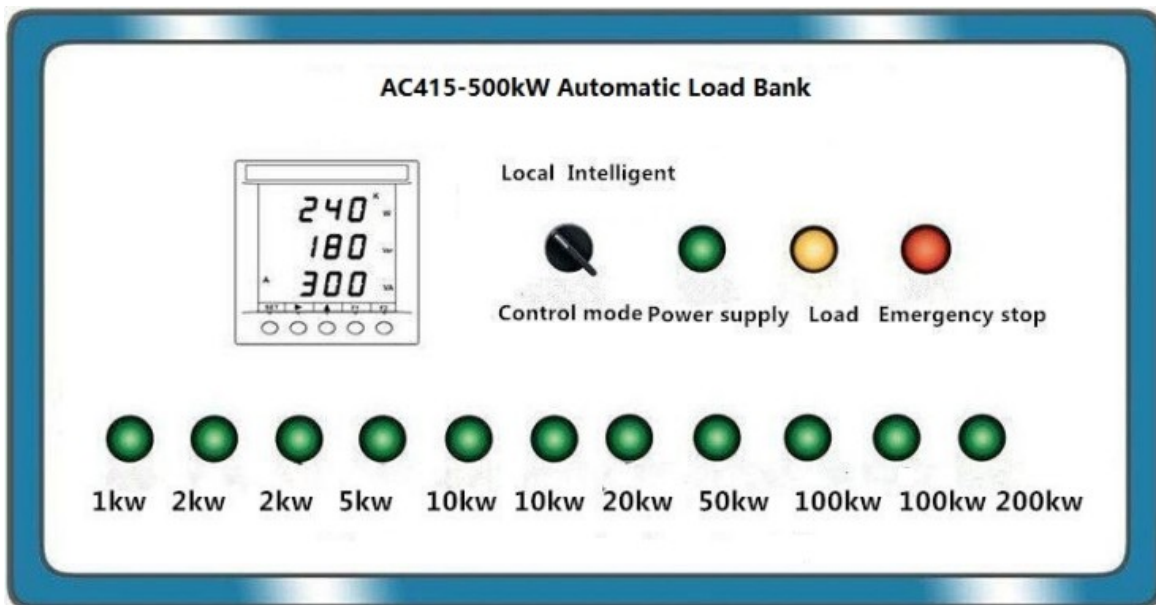

ControlPanel

8. DataProcessingSoftware



The data processing software is installed in the notebook or PC, customer can connect computer and load bank by data transmission line, and then realize all the test function by intelligent control through the software

(1) Main

Interface: the software can realize many functions, such as adding load, data collecting, storage, management and so on.

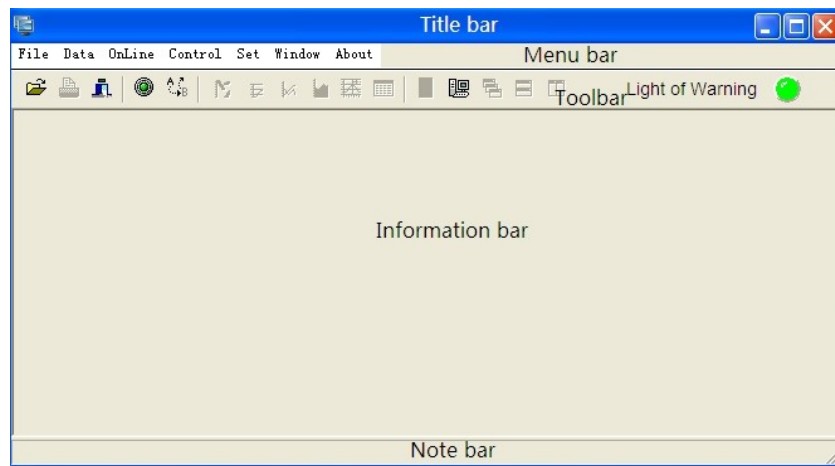

nt and so on.

(2) AddLoad: there are two modes to choose, manual operation or auto.

1) Manual Loading: customer selects and sets the power value, then the system adds the load continuously.

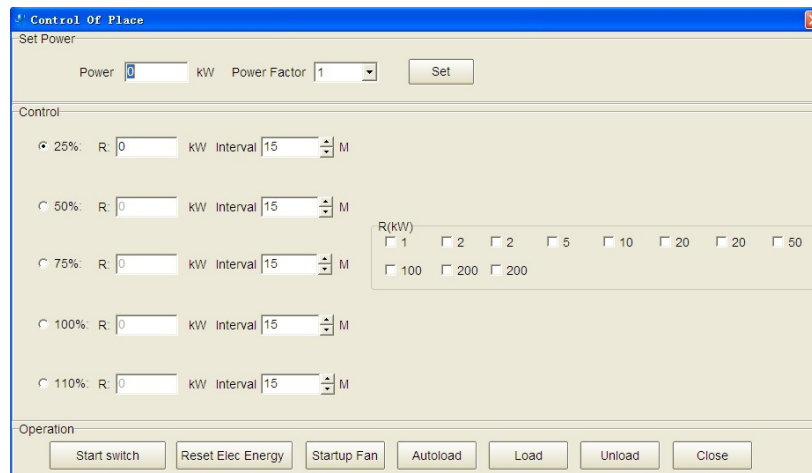

2) **Automatic Loading:** customer can set several add stage, each stage can be different in power antime, system completes the add process according this order: 0%→25%→50%→75%→100% or 110%.

(3) **Data Display:** it can display the real-time data, curves and graphs. Customer can save data at anytime, and set data storage of interval time freely.

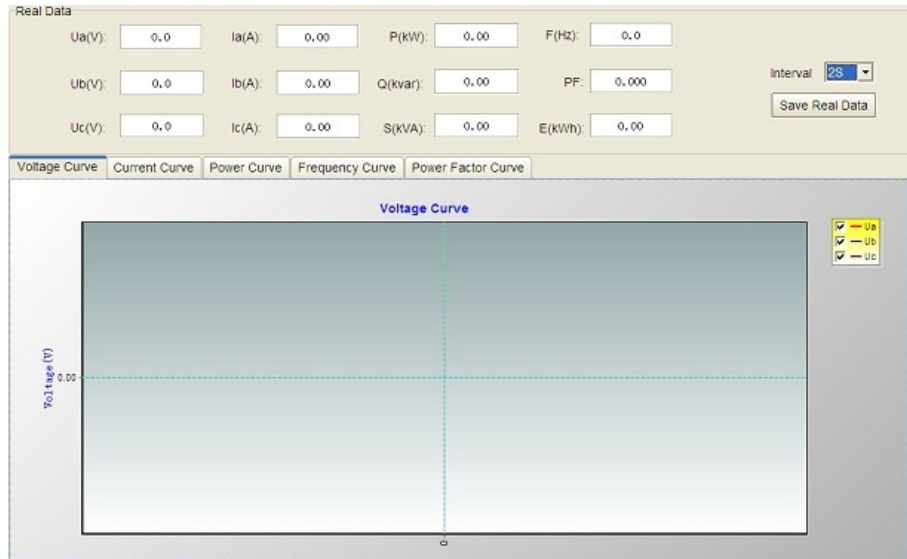

(4) **Data Management:** after testing, customers should save useful data, and you can query and print at anytime.

1) **Data Query:** customer can read testing record which is saved in the past, and view all the data in curve graphs or forms.

Test Time	Running Time	Test Name	Operator
2012-10-19 16:44:16	0M4S	1	1
2012-10-18 16:23:51		522	2445
2010-02-09 9:55:18	0M12S	09	09
2010-01-26 10:58:19	0M0S	dd	dd
2010-01-26 10:17:49	8M20S	vtff	ff
2010-01-15 11:29:29	1M14S	vrtt	tt
2009-09-07 18:26:12	17M48S	121	120
2009-09-07 14:04:00	9M42S	44333	44
2009-09-07 14:01:08	2M4S	11222	44
2009-09-07 12:51:58	10M6S	2222	11

2) **Print:** customer can choose the testing data curve or graph you need to print.

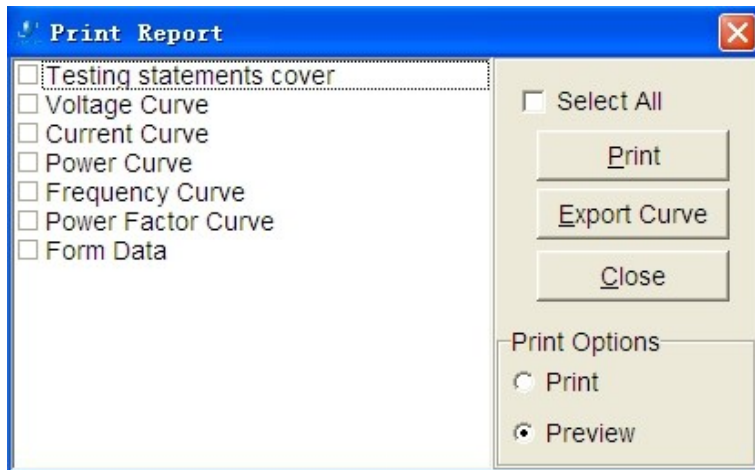

Current curve

Voltage curve

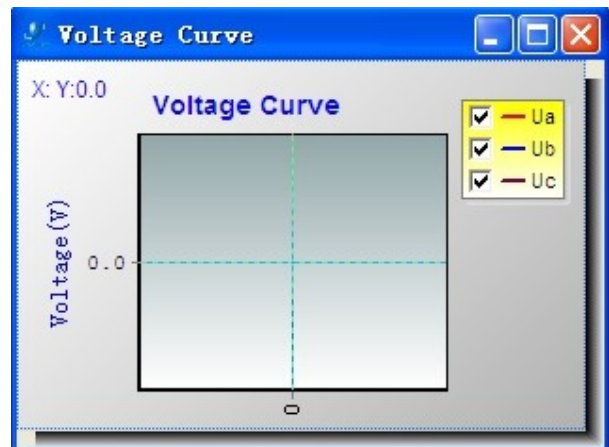
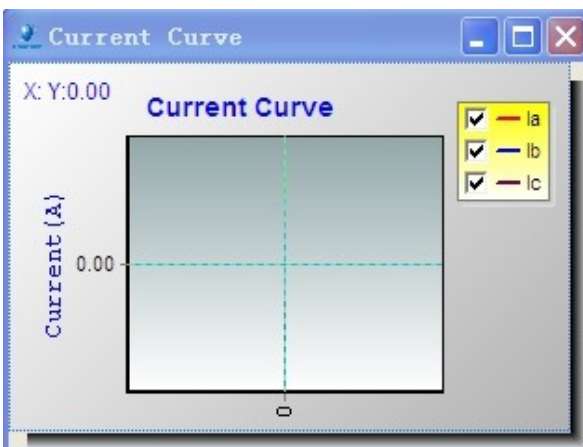
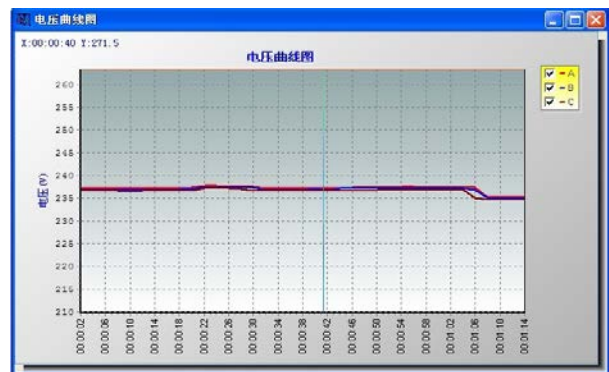
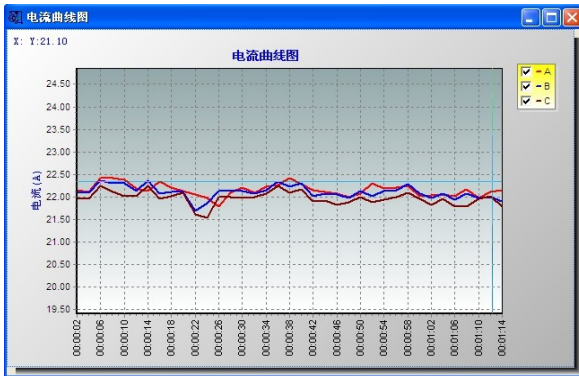

Powercurve

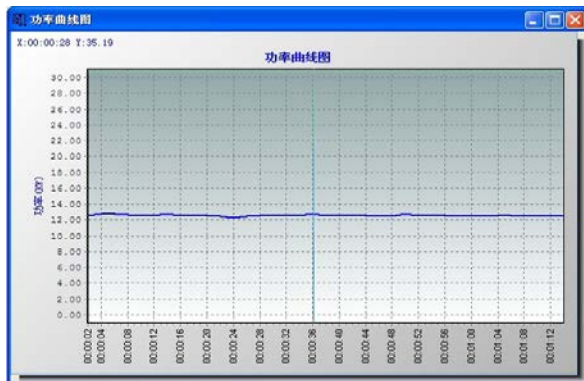

Data

Time	Voltage(V)			Current(A)			P(kW)	Q(kvar)	S(kVA)	F(Hz)	PF	E(kWh)
	A	B	C	A	B	C						
00:09:20	230.3	231.5	230.6	0.00	0.00	0.00	0.00	0.00	0.00	50.0	0.000	0.43
00:09:22	230.3	231.5	230.6	0.00	0.00	0.00	0.00	0.00	0.00	50.0	0.000	0.43
00:09:24	230.3	231.5	230.6	0.00	0.00	0.00	0.00	0.00	0.00	50.0	0.000	0.43
00:09:26	230.3	231.5	230.6	0.00	0.00	0.00	0.00	0.00	0.00	50.0	0.000	0.43
00:09:28	230.3	231.5	230.6	0.00	0.00	0.00	0.00	0.00	0.00	50.0	0.000	0.43
00:09:30	230.3	231.4	230.7	0.00	0.00	0.00	0.00	0.00	0.00	50.0	0.000	0.43
00:09:32	230.3	231.4	230.7	0.00	0.00	0.00	0.00	0.00	0.00	50.0	0.000	0.43
00:09:34	230.3	231.4	230.7	0.00	0.00	0.00	0.00	0.00	0.00	50.0	0.000	0.43
00:09:36	230.3	231.4	230.7	0.00	0.00	0.00	0.00	0.00	0.00	50.0	0.000	0.43
00:09:38	230.3	231.4	230.7	0.00	0.00	0.00	0.00	0.00	0.00	50.0	0.000	0.43
00:07:36	230.2	231.2	230.6	0.00	0.00	0.00	0.00	0.00	0.00	50.0	0.000	0.43
00:07:38	230.3	231.3	230.7	0.00	0.00	0.00	0.00	0.00	0.00	50.0	0.000	0.43
00:07:40	230.3	231.3	230.7	0.00	0.00	0.00	0.00	0.00	0.00	50.0	0.000	0.43
00:07:42	230.3	231.3	230.7	0.00	0.00	0.00	0.00	0.00	0.00	50.0	0.000	0.43
00:07:44	230.3	231.3	230.7	0.00	0.00	0.00	0.00	0.00	0.00	50.0	0.000	0.43
00:07:46	230.3	231.3	230.7	0.00	0.00	0.00	0.00	0.00	0.00	50.0	0.000	0.43
00:07:48	230.3	231.3	230.7	0.00	0.00	0.00	0.00	0.00	0.00	50.0	0.000	0.43
00:07:50	230.3	231.3	230.7	0.00	0.00	0.00	0.00	0.00	0.00	50.0	0.000	0.43
00:07:52	230.3	231.3	230.7	0.00	0.00	0.00	0.00	0.00	0.00	50.0	0.000	0.43
00:07:54	230.3	231.3	230.7	0.00	0.00	0.00	0.00	0.00	0.00	50.0	0.000	0.43
00:07:56	230.1	231.3	230.5	0.00	0.00	0.00	0.00	0.00	0.00	50.0	0.000	0.43
00:08:00	230.1	231.3	230.5	0.00	0.00	0.00	0.00	0.00	0.00	50.0	0.000	0.43
00:08:02	230.1	231.3	230.5	0.00	0.00	0.00	0.00	0.00	0.00	50.0	0.000	0.43

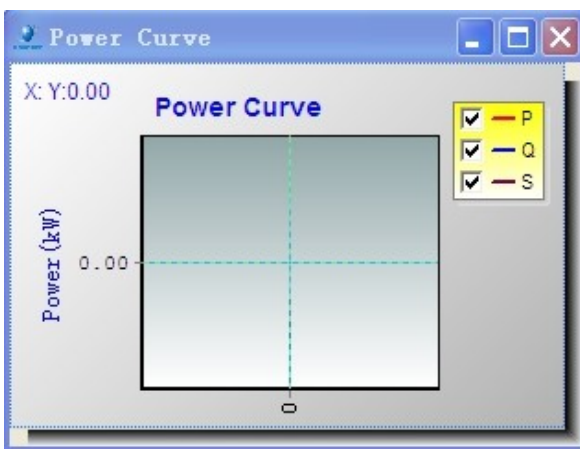

9. Resistor

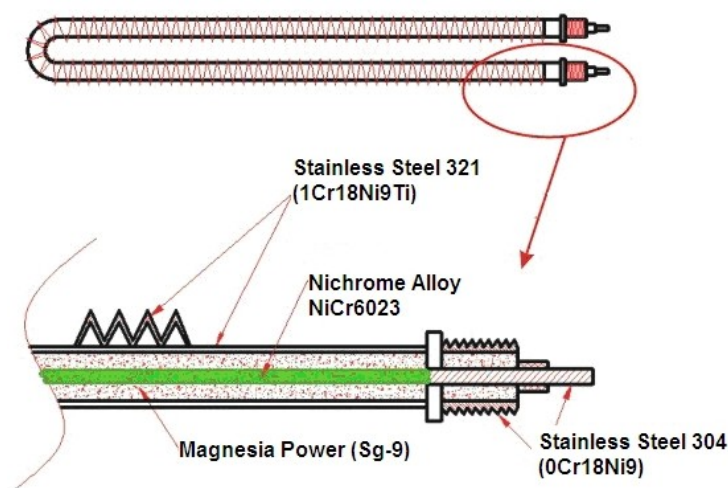

Resistive load consists of special alloy resistors. There is cooling fin outside, filled with insulation medium, resistor is in insulation medium, it can meet load testing requirements. Alloy resistor is with high insulation performance, uniform heat conduction. Running temperature is only 1/3 of

designed temperature, low temperature drift, steady resistance, no red-hot in long time running. Acid alkaline resistant, salt fog resistant, waterproof, moisture proof, anti corrosion for all weather use. With exclusive technology, alloy resistor is fixed in insulated material palette; the whole resistive load is blocked, insulated by inner insulation and insulation plate, make sure the good insulation and safety even in wet weather and prevent short circuit because of next resistor value decreases.

(1) Alloy resistor adopt nichrome (NiCr6023), anti temperature (max working temperature reach up to 1300°C), steady electrical performance, low temperature drift ($5 \times 10^{-5}/^{\circ}\text{C}$), this technology is the most advanced in alloy resistor manufacturing.

(2) The tube adopts extensibility and resistance oxidation Stainless Steel 304 (0Cr18Ni9), filling material export grade electrical crystallization magnesium oxide powder (Sg-9), performance standards JBY-TE4088-199, magnesium density $3.0\text{g}/\text{cm}^3 \pm 0.2$, screws is anti-corrosion, anti-temperature Stainless Steel 304 (0Cr18Ni9). With strict and clear material control, the mass produced alloy resistor are with highly congruent performance.

(3) Cooling fin Stainless Steel 304, height $7\text{mm} \pm 2$, thickness $0.4\text{mm} \pm 0.2$, winding interval no more than $3\text{mm} \pm 0.2$.

(4) When each resistor withstand voltage is DC3000V or 1500V, 50Hz, 1 minute without puncture. Multi alloy resistor connection in series, make sure withstand voltage reach 20kV.

(5) Cooling fin uniform temperature no more than 300°C , max 320°C , there is enough margin to make sure alloy resistor can be working continuously, resistor max temperature 1300°C .

(6) When resistor temperature reach 300°C to 400°C , temperature drift is also less than $\pm 2\%$, it assure the resistance value no much changes in high temperature working condition, thus loading steady power could be available in any temperature.

(7) Whether in max and min temperature, load accuracy is no more than 3%

(8) Air outlet temperature no more than 80°C (within 1 meter)

10. Main Circuit

The system control load/unload through control breaker. The contactor use main contact point to open and close the circuit, execute control instruction by auxiliary contact, contact made by silver-tungsten alloys, with good electrical conductivity and high temperature resistance.

MCB used to short circuit protection, which is a kind of manual switch, with short circuit protection and insulation protection function. No need change new one after short circuit, to protect the circuit and equipment.

11. Power Circuit



Contactor



Fuse

The circuit of power circuit controls the load running with control and protective model of contactor-fuse. Each load step is with one contactor-fuse.

Loading power changes by contactor's switch. Contactor opens and closes circuit through main contacts, through auxiliary contact to carry out control instruction. Contacts are made of silver-tungsten alloys with good electric conducting performance and high temperature ablation.

Fuse is used to short circuit protection. Fuse element is made of low melting point metal, when current passing through fuse exceeds safety value, the heat will make fuse element melting to cut off circuit to protect electrical circuit and equipments.

12. Control Module

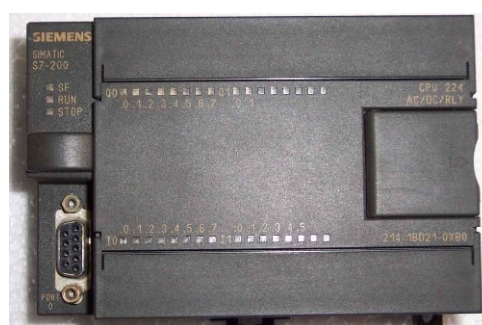

Load control module is the pivot which makes load/unload, protection, etc automatically.

The module with following features:

1、 High stability, high anti-interference capacity.

① Long MTBF;

② Short Fault Correction Time (MTTR);

Hardware measure: main module adopts large scale or very large scale integration circuit, large number of on-off action finished by contactless electric storage, I/O system design with thorough passageway protection and signal processing circuit.

① Shield ; ② filtering ; ③ power supply adjustment and protection ; ④ isolation ; ⑤ adopts modular structure;

Software measure: with strong self-inspection and protection function.

① Fault detect; ② Information protection and recovery; ③ setting watchdog timer WDT

(watchdog) ; ④ Reinforce check and verify top program ; ⑤ battery reserve top program and dynamic data ;

2、 High commonality, variable control program, easy to use.

Powerful function, wide adaptation.

PLC besides function of logical operation, time, count, sequential control, also with function of input & output of digital, analog quantity, power drive, self-inspection, record display etc.

4、 Simple programming, easy to learn.

5、 Reduce the workload of control system design and construction. PLC adopts software to replace vast intermediate relay, timer relay, counter of relay control system, will reduce the design, installation, wire connection work of control cabinet.

6、 Small volume, lightweight, low power dissipation, easy to maintain.

PLC is product apply micro electronic technique to industrial equipment, compact structure, solid, small size, low power dissipation. Because the strong anti-jamming capability, easy to install inside of equipment, PLC ideal control equipment of mechatronics

13. Cooling Fan



Load bank cooling system is made up of axial flow fans and automatic protective devices, blow away heat conversion from power module, keep inside of enclosure with suitable temperature.

(1) The fans adopt dedicated waterproof motor and variable corrosion resistance impeller, the fan delivery is 22000 cubic meter/hour, through combination of multi sets fans, fully satisfied the cooling requirement of the load bank.

There are transducers/sensors and over load protective devices, automatic load dump and give alarm when load bank is abnormal. Many temperature sensors are put in load elements and air outlet to cut off load to protect load bank when temperature reach warning value.

As to the main components of load bank, we choose international advanced and experienced reliable elements to assure the high quality.

(2) Use wind speed tester AVM-03 to test the air outlet, the average wind speed is 8-10m/s. Use noise meter DT-815, the working noise is ≤ 85 dB(3M), high blast capacity and low noise.

(3) The fan equip with blast capacity detection sensors and motor overload protector, auto cut off the load and send alarm under abnormal condition. It install several temperature sensor and load part and air outlet position, it also will cut off load when temperature reach warning value, make sure the load bank will not damaged because of over temperature.

14. After-sale Service

(1). Warranty period is one year.

(2). If required, technicians will be sent to help customer install and debug the machine.

(3). We can provide training service on site for customer' technicians to meet the requirement of daily work and maintenance.

(4). Customer has the right of technical consulting service for free forever. (5). Long time spare parts supply.